

### SUA-110M8A-30x-S372

鍍層厚度：

Blank : 1u"
2 : 15u"
3 : 30u"

### RECOMMENDED PCBA LAYOUT

NOTE:

1.MATERIAL:

- 1.1 Housing: LCP
- 1.2 Contact: Phosphor Bronze
- 1.3 Shell: Brass

2.Finish:

- 2.1 Contact: Plated Gold in Mating Area ;  
Tin Plated on Solder Balls ;  
Nickel under plated overall
- 2.2 Shell: Nickel under Plated surface layer

3.SPECIFICATION:

- 3.1 Current Rate: 1.5 A
- 3.2 insulator Resistance: 100MΩ Min
- 3.3 Dielectric Strength: 100V AC
- 3.4 Contact Resistance: 30mΩ Max
- 3.5 Operation Temperature: -40°C ~ +85°C

Pin NUMBER	SIGNAL NAME
1	VBUS
2	D-
3	D+
4	GND
5	StdA_SSRX-
6	StdA_SSRX+
7	GND_DRAIN
8	StdA_SSTX-
9	StdA_SSTX+
Shell	Shield

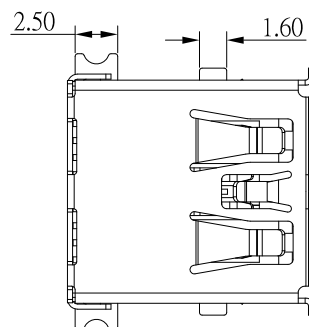

TOLERANCE UNLESS OTHERWISE STATED:  
 Up to 5 ±0.2  
 Above 5 ~ 15 ±0.3  
 Above 15 ~ 30 ±0.4  
 Above 30 ~ 50 ±0.5  
 Angle ±0.3

3RD. ANGEL'S



UNITS MM

DRAWN BY: Jack Lu  
 CHECKED BY: Jacky Chen  
 APPROVED BY: Tony Kao

DATE: 03/23/23  
 DATE: 03/23/23  
 DATE: 03/23/23

MAT'L		TITLE	CONNECTOR
FINISH		MODLE	USB 3.0 AF SMT 外殼四腳全貼本體長=14.60mm, 板上高7.0 有捲邊 有定位柱
SCALE	1 : 1	DWG NO.	SUA-110M8A-30x-S372
SHEET NO.	1 of 1	PART NO.	SUA-110M8A-30x-S372
		SIZE	A4
		VER	R

ITEM NO.	DESCRIPTION	DRAWN	DATE